

[www.kapelectronics.net](http://www.kapelectronics.net)

---

## Instructions to build a balloon cradle

---

### Introduction:

Objectives in the design of this cradle were:

- Very low cost.
- Parts easy to find everywhere.
- Lightness, permitting the use of small kites.
- Easy to build.

As far as we know, the balloon cradle is a quite original concept based on a disposable camera released by the deflation of a child toy balloon.

This very simple cradle is the perfect model to start out in Kite Aerial Photography. You will find in this page all detailed instructions to build the cradle and make your first aerial picture within hours.

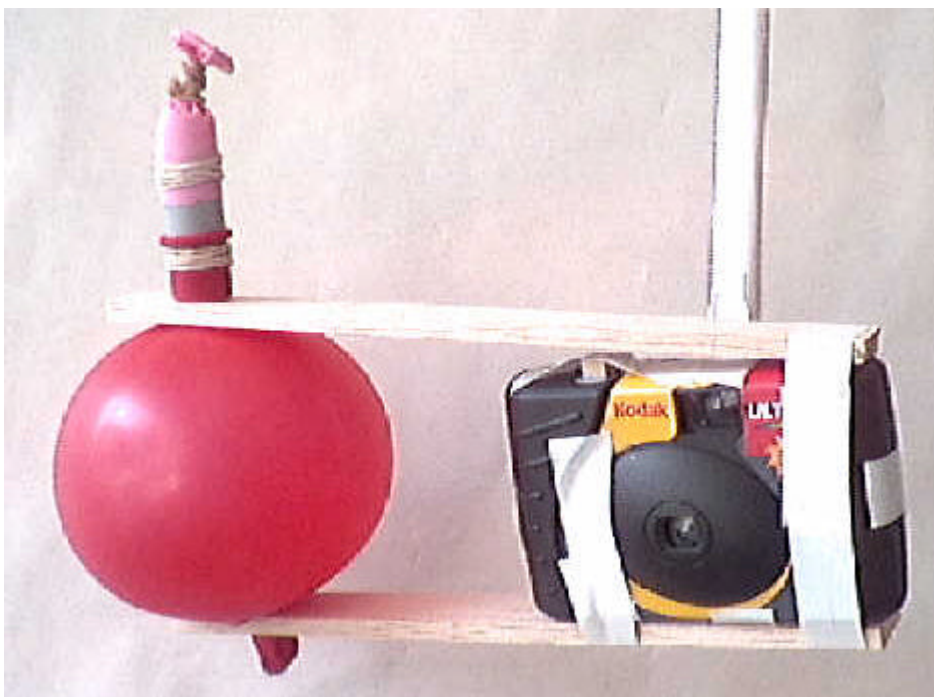

### Specifications:

- Standard disposable camera.
- Building with standard and easy to find parts.
- Release delay adjustable from 1 to 5 minutes.
- Delay accuracy: +/- 1 minute.
- Visual information of the release time.
- Total weight with Kodak Ultra camera: 95g.
- Extremely low weight permitting to fly the cradle with a child toy kite.



**Instructions:****1. Bill of materials:**

- 1 standard disposable camera with the release button located on top
- 2 medium size child toy balloons
- 50cm length of wood, 5mm x 20mm section
- 20cm x 30cm cardboard sheet
- 1 piece of plastic pipe, 4cm long and 1,5cm diameter
- 5cm copper or iron wire
- 3 rubber bands
- 1 strong adhesive tape



Parts

**2. Tools:**

- Handsaw
- Drill
- Chisel
- Sewing needle
- Lighter

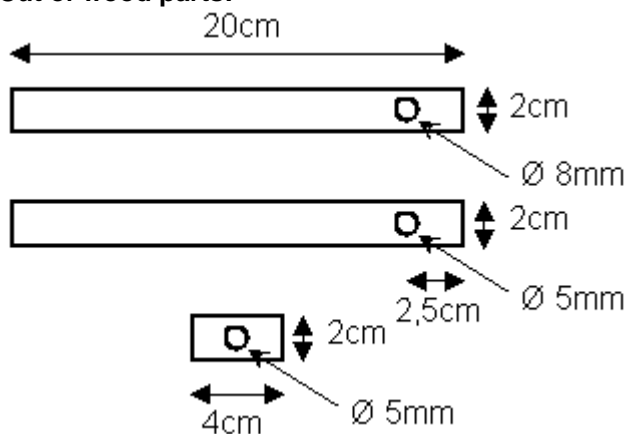
**3. Cut of wood parts:**

Be cautious to respect the diameter of holes (5mm and 8mm).

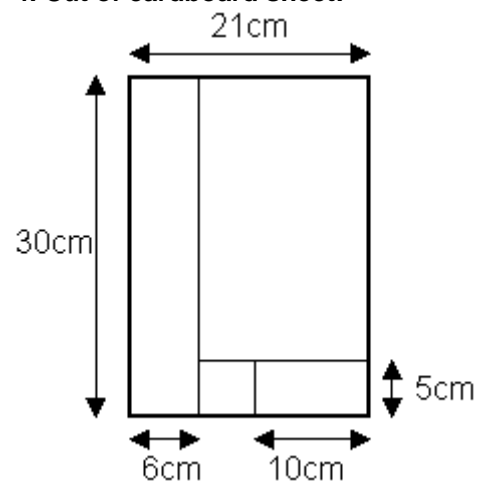
**4. Cut of cardboard sheet:****5. Building of the balloon release system:**

**5.1.** Make a little hole in the middle of the plastic pipe with the needle heated with the lighter. Be careful to make the hole as little as possible: it will be possible to enlarge it after if the airflow is to low.



**5.2.** Cut the balloon as shown on the picture.



**5.3.** Put the 2 balloons and the plastic pipe together as shown. Hold together with 2 rubber bands. Keep the airflow hole clear.



**5.4.** Put the balloon and the 2 wooden parts together: the balloon go through the 8mm hole first, then through the 5mm hole. Inflate the balloon to check if all is right. The balloon shall be strongly fixed in the 5mm hole without slipping.

## 6. Building the cradle:



**6.1.** Cut a 5mm cubic wooden part. Fix this part with adhesive tape on the release button of the camera as shown on the picture.



**6.2.** Fold the 5cm x 10cm cardboard part as shown, and fix it on the back of the camera with tape. Be careful to keep clear the film winding.



**6.3.** Fix the 2 wooden parts with adhesive tape. The right adhesive tape piece is put around the camera and firmly fasten the 2 wooden parts. The left adhesive tape fixes only the bottom wooden part.



**6.4.** Check that the tension produced by the balloon is sufficient to correctly release the camera shutter. If not, adjust it by slipping the balloon into the 5mm hole of the bottom wooden part.



**6.5.** Make a pipe by rolling up the 30cm x 6cm cardboard part. Fix it with adhesive tape.



**6.6.** Drill 2 holes at the end of the pipe and fix the piece of copper wire.



**6.7.** Fix the other end of the pipe as shown. Add a piece of adhesive tape around the assembly to make it more rigid.



**6.8.** Fold the 25cm x 15cm cardboard piece as shown and make 2 holes with the copper wire to fix the pipe.

## 7. Hanging the cradle on the line:



7.1. Fix the stop part on the line as shown.



7.2. Slip the line into the folded cardboard. Add adhesive tape on short sides. Bend the copper wire on both ends to fasten the assembly.

## 8. Cradle test:

Inflate the balloon so as to free the camera release button. Close the balloon with a rubber band.

Time the delay and check that the button is correctly released when the balloon is deflated.



start



delay



released



released

### **Instruction to take photos with the balloon cradle:**

1. Take off the kite with a minimum of 30m of line. Check that the kite is stable enough to hang the cradle.
2. Fix the stop on the line (see 7.1.).
3. Hang the cradle in front of the stop. Add adhesive tape to prevent the line from escaping (see 7.2).
4. Inflate the balloon and close it with a rubber band.

5. Wind on the film.
6. Give some line to make the cradle go up.
7. Monitor the release delay by watching the size of the balloon. Stop giving line when release is imminent to stabilize the kite.
8. When the balloon is deflated, take the cradle down by rewinding the line, and resume in 4 to take a new picture.

### **Kite selection:**

The extremely low weight of this cradle permits the use of small kites, as children kites you can find in toy shops. The only condition is that the kite is reasonably stable.

It is also possible to use a two lines kite if you have one and have a good control of it.

Copyright 2000 Olivier HUMEZ

Use or reproduction of this document or data it contains for commercial purpose is strictly forbidden.

Web page: [www.kapelectronics.net](http://www.kapelectronics.net)

E-mail: [contact@kapelectronics.net](mailto:contact@kapelectronics.net)